

# OCEANIS 46.1

## E-BOOK



**BENETEAU**  
AVANT-GARDE IN BOATING



BENETEAU

First Line carbon Pack  
Grey Pearl hull  
Lite Skin Performance sails



# 1. Key Points

# Oceanis 46.1

## E -BOOK



### A bestseller is born:

The Oceanis 46.1 is the ideal design to successfully follow up the iconic Oceanis 45, which has an impeccable track record. She retains the fundamental elements, which have proved such a hit among our clients, such as volume and comfort, whilst harmoniously integrating the codes that make the 51.1 so popular: innovative hull, improved performance and elegance.

An extremely well-designed boat to guarantee a long career that extends far beyond the others.



## SPECIFICATIONS

• L.O.A	14,60 m / 47'11"
• Hull length	13,65 m / 44'9"
• L.W.L.	13,24 m / 43'5"
• Beam	4,50 m / 14'9"
• Deep draft (Cast iron)	2,35 m / 7'9"
• Deep ballast weight	2 735 kg / 6,028 lbs
• Shallow draft (Cast iron)	1,75 m / 5'9"
• Shallow ballast weight	3 061 kg / 6,746 lbs
• Performance draft (Cast iron/Lead)	2,65 m / 8'8"
• Ballast weight performance	2 576 kg / 5,678 lbs
• Air draft	20,31 m / 66'8"
• Air draft (Performance mast)	21,31 m / 69'11"
• Light displacement	10 597 kg / 23,356 lbs
• Fuel capacity (standard)	200 L / 53 US Gal
• Fuel capacity (Option)	200 L / 53 US Gal
• Fresh water capacity (standard)	370 L / 98 US Gal
• Fresh water capacity (Option)	200 L / 53 US Gal
• Engine power (standard)	57 HP / 57 HP
• Engine power (Option)	80 HP / 80 HP

- Naval Architect: Pascal Cong
- Outside & interior design: Nauta Design

## STANDARD SAILS DIMENSIONS

• Furling mainsail (standard)	44,50 m <sup>2</sup> / 479 sq/ft
• Self-tacking jib (standard)	40,42 m <sup>2</sup> / 435 sq/ft
• Classic mainsail	54 m <sup>2</sup> / 581 sq/ft
• Furling genoa (105 %)	52,16 m <sup>2</sup> / 561 sq/ft
• Code	0 102 m <sup>2</sup> / 1,098 sq/ft
• Asymmetrical spinnaker	152 m <sup>2</sup> / 1,636 sq/ft
• I	17,72 m / 58'2"
• J	5,72 m / 18'9"
• P - Roller furling mast	16,57 m / 54'4"
• P - Classical mast	16,82 m / 55'2"
• E	5,630 m / 18'6"

## PERFORMANCE (Extended classic mast)

• Classic mainsail	57,60 m <sup>2</sup> / 620 sq/ft
• Genoa	57,80 m <sup>2</sup> / 622 sq/ft
• I	18,33 m / 60'2"
• J	5,71m / 18'9"
• P	17,82 m / 58'6"
• E	5,63 m / 18'6"

1 boat / 3 dedicated programs



## Even more volume thanks to the 51.1's innovative hull

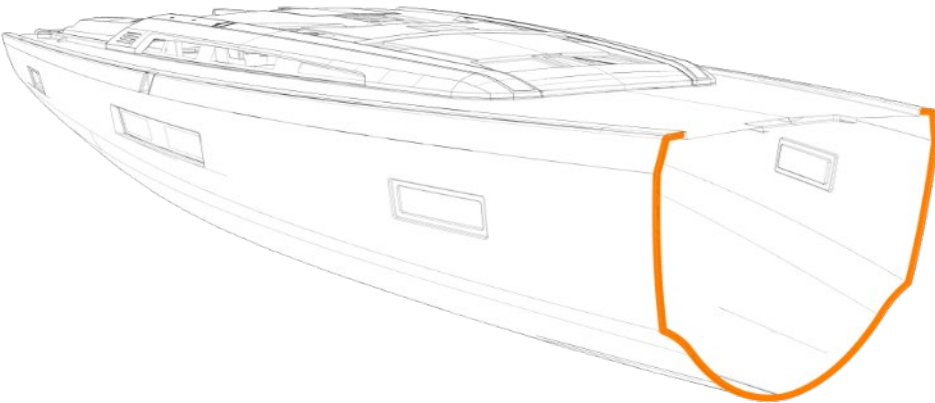

Situated above the waterline, the chine boosts the internal volume considerably, retaining the boat's seaworthy qualities and the performance of the hull.

This increase in space is striking in the forward cabin: +50 cm / 1'8" gain in hull width compared with the Oceanis 45: the only boat of this size on the market with an owner's cabin. Everything has been designed for optimum comfort and volume.

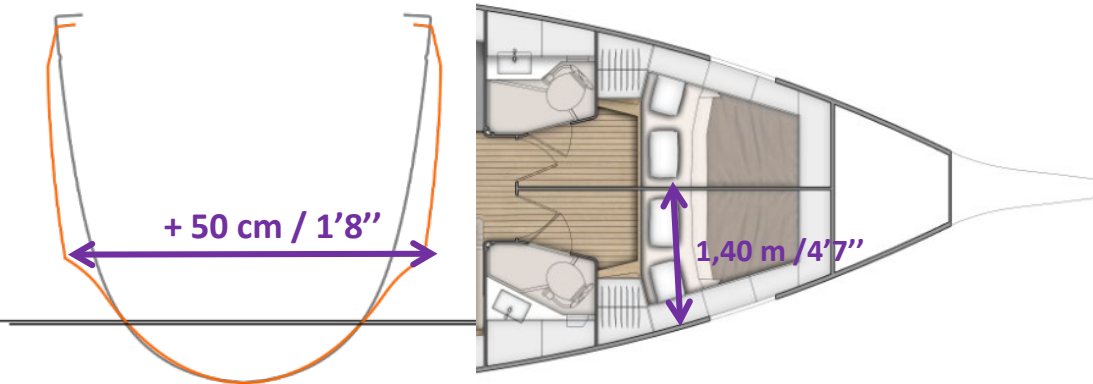

An architectural choice, which also benefits from 2 specific forward cabin options with a comfortable double bed that measures 1.40m / 4'7" at the bedhead.

A key asset for Yacht management or Charter sales



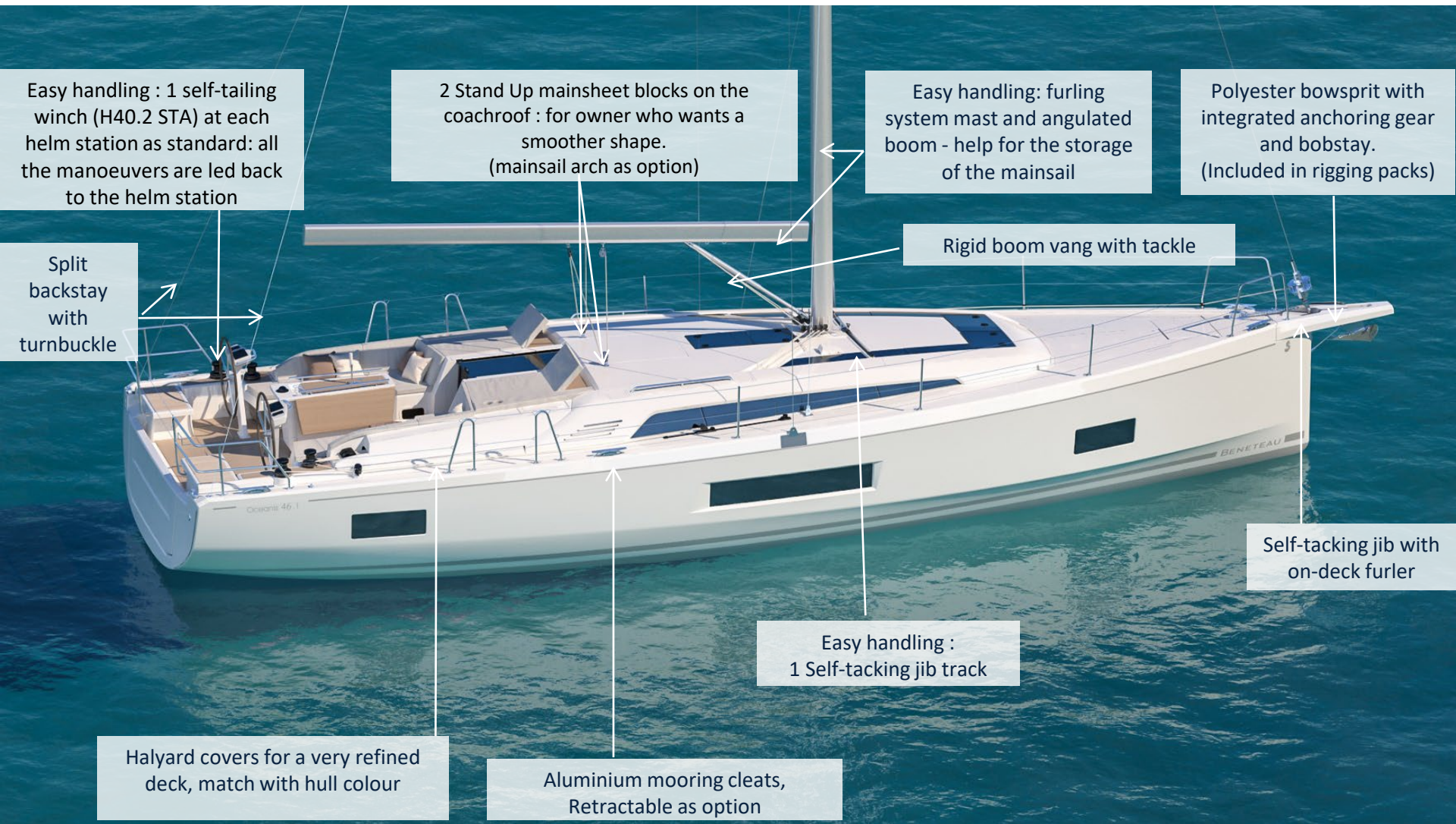

Easy handling : 1 self-tailing winch (H40.2 STA) at each helm station as standard: all the manoeuvres are led back to the helm station

2 Stand Up mainsheet blocks on the coachroof : for owner who wants a smoother shape.  
(mainsail arch as option)

Easy handling: furling system mast and angulated boom - help for the storage of the mainsail

Polyester bowsprit with integrated anchoring gear and bobstay.  
(Included in rigging packs)

Split backstay with turnbuckle

Rigid boom vang with tackle

Self-tacking jib with on-deck furler

Easy handling :  
1 Self-tacking jib track

Halyard covers for a very refined deck, match with hull colour

Aluminium mooring cleats,  
Retractable as option



# Oceanis 46.1

## E -BOOK



Easy movement in complete safety



Lower shroud fixed inside :  
easy movement towards  
forward

Handrails on the roof

Safety moves: Double guard  
lines and stainless steel  
stanchions 650 mm / 2'2"

Comfortable side decks





Mainsail arch option

Side gates option

Helm console (included in electronic pack) mounted on a pedestal

Wide and very spacious cockpit to make it comfortable and easy to move around.

The sunbathing areas adjacent to the companionway considerably increase the hosting capacity and are always available for lounging.

Choice of 2 large cockpit tables.

Both are able to stow the life raft in the central section

2,65 m x 0,80 m / 8'8" x 2'7"

Large bathing platform with an integrated ladder  
Optional electric opening.

Port helmsman's seat: integrates 2 gas bottle stowage (Diameter : 0,28 m / 11" x Height : 0,44 m / 1'5")

Starboard helmsman's seat: integrated stowage locker

## A unique cockpit: space, ergonomics, comfort

Cockpit seating extension with integrated rope locker (trim level)

L-shaped cockpit seating: to provide good support when heeled or for use as a lounge

3.15m / 10'4" relaxation area on each side of the cockpit!  
The sunbed areas continuing on from cockpit seating are an extension of the cockpit, thus providing comfortable additional space aboard for guests. A choice, which enables a large fixed cockpit table that is always able to be used

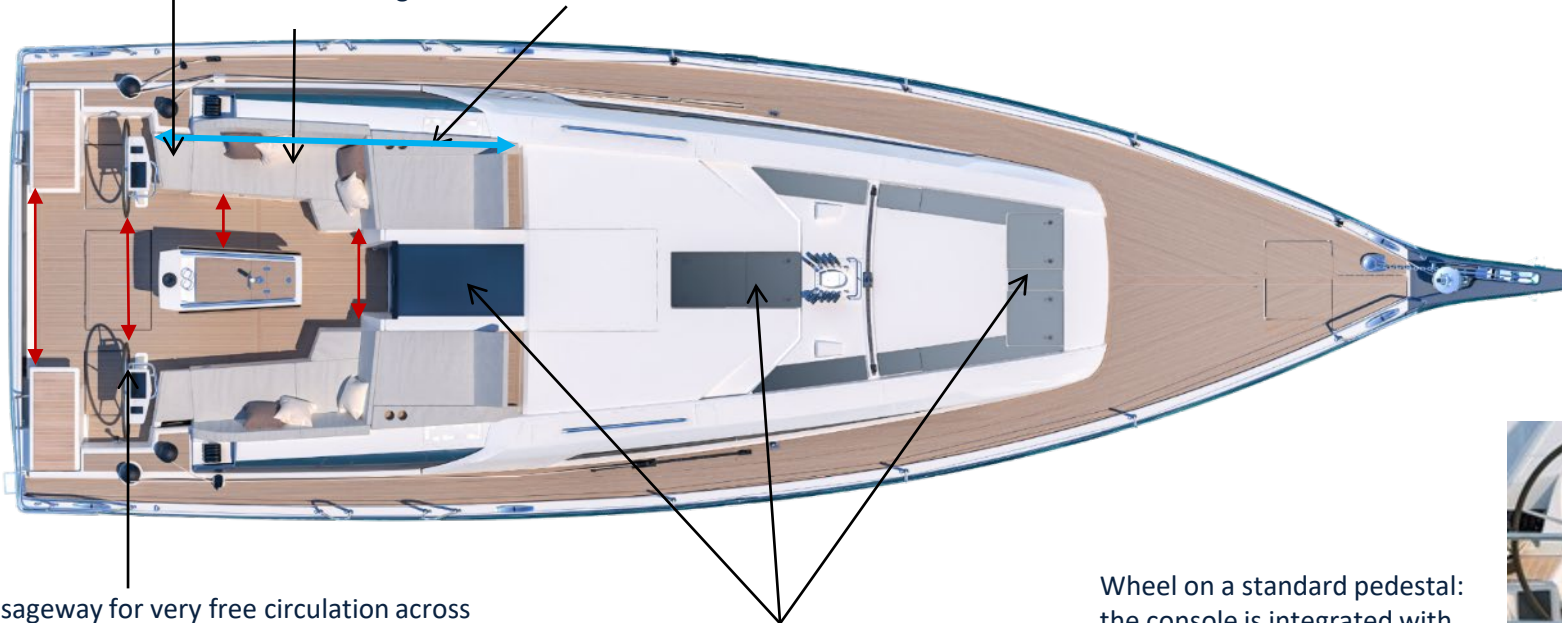

Wide passageway for very free circulation across the whole cockpit: access to the platform, between the wheels, around the cockpit table and near the companionway

Large windows for excellent interior light.  
3 opening deck hatches

Wheel on a standard pedestal: the console is integrated with the electronic instrument packs

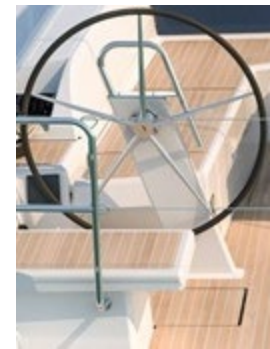



# Oceanis 46.1

## E-BOOK

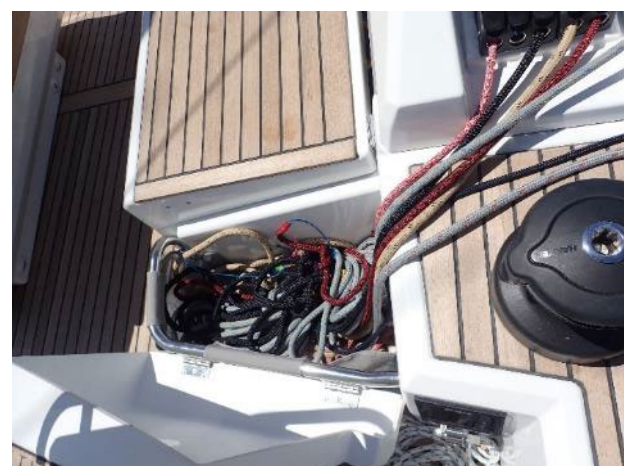

# Oceanis 46.1

## E -BOOK

### Helm consoles & Electronic Packs



1 starboard helm console with Coastal Pack

2 helm consoles with Offshore Pack





Oceanis 46.1

E-BOOK



Electronic Pack with large consoles



## Electronic Pack with large consoles

Includes:

Raymarine Coastal + Offshore Pack with 9" screen instead of 7"

+ Electric engine control

+ Bow thruster control

+ Windlass control

+ Pilot control

+ Aft Platform control (control works only if BE P19E electrically opening for the aft platform is chosen)

**Requires bow thruster option.**

### Port steering console

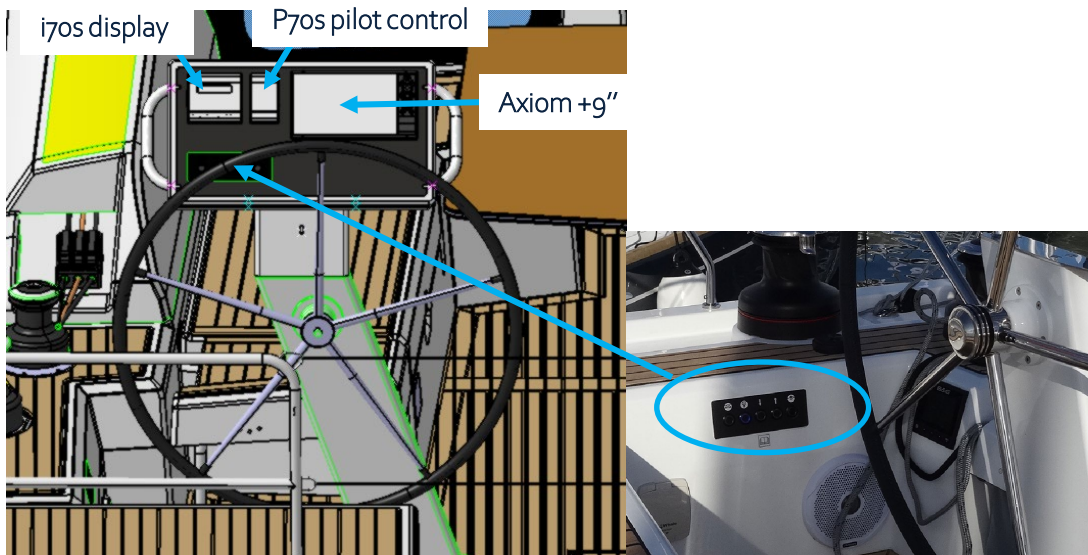

### Starboard steering console

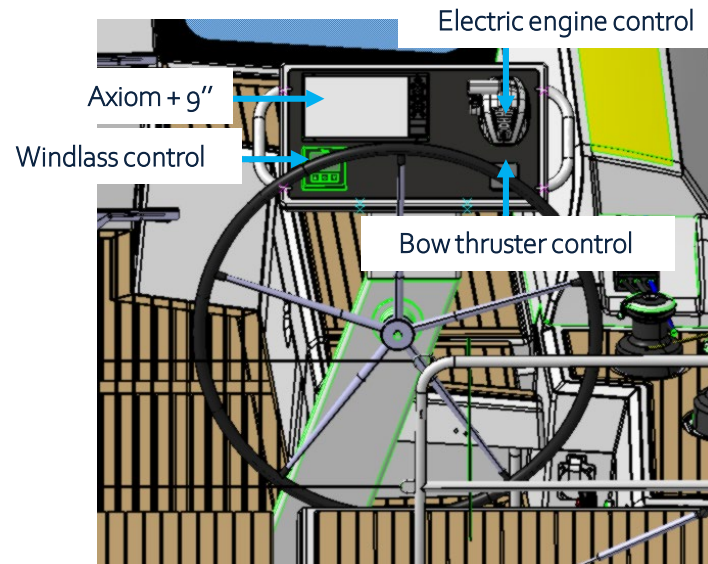



### Cockpit: comfort options

Companionway sunbeds with removable upholstery (option) : can be very easily moved on fore deck

Clever: sunbeds with tilting backrest and integrated cup holders



2 choices for exterior upholsteries

- Cushions and backrests
- 2 Companionway sunbeds



## Cockpit: comfort options



### Gas cockpit plancha option

Increase the welcome capacity : add a long seat beside helmsman :  
0,80m x 0,47m / 2'7" x 1'7"

Smart : rotates toward the aft platform for an ergonomic position and to use it without bothering the life in the cockpit.

Handrail on the side to cook in complete safety





## Cockpit: comfort options



### "Luxe" cockpit table option

"Luxe" polyester/wood cockpit table + protective cover (Cadet Grey), stainless steel handrails, waterproof USB plug, central storage (15 L / 4 US Gal)

The storage can be converted as cooler with the refrigerating unit as option

Liferaft storage in the central section

'Luxe' cockpit table included in Charter trim level with polyester flaps for an easier maintenance



### Dimensions:

central section dimension =

1,30 m x 0,50 m / 4'3" x 1'8"

Wooden leaves =

1,10 m x 0,40 m / 3'7" x 1'4"

Opened width =

1,35 m / 4'5"



### Cockpit: comfort options

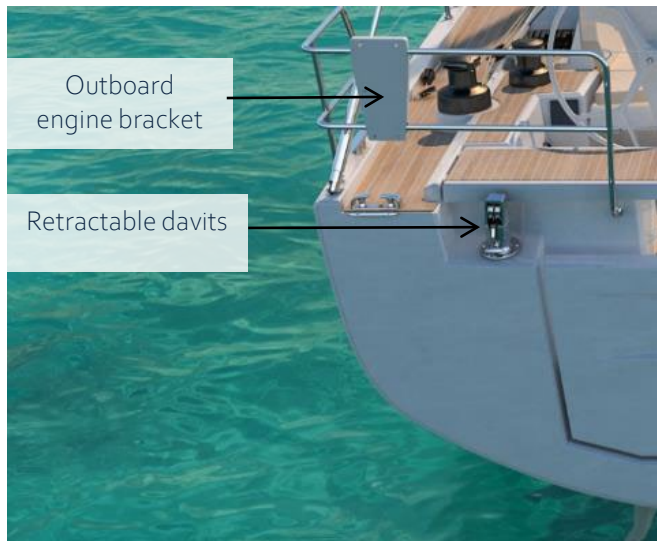

### TENDER PACK

- Retractable davits  
(Max. tender length: 3,10 m / 10'2", Maximum load: 130 kg / 287 lbs)
- Electric inflater / deflater
- Outboard engine bucket

A convenient solution for the dinghy stowage



### Cockpit: comfort options

#### EXTERIOR PROTECTIONS LUXE CADET GREY

2 Versions: with and without mainsail arch

- Sprayhood with large Extra-Clear windows provide excellent visibility
- Bimini delivered with shading canvas and LED lighting
- Aft enclosure option : allows the cockpit to be a full time additional living area whatever the weather is (no visual)



## RIGGING PACKS: FOR EASIER ORDERS AND BETTER UNDERSTANDING

1

FURLING MAST  
(Standard boat)



OR



CLASSIC MAST PACK  
With mainsail and lazy  
bag

OR



**FIRST LINE**

Boat delivered without  
sails.

1. Chose your mast:  
furling/ classic/ Performance

2. Chose 1 rigging pack according your  
customer's navigation program

Packs are thought to fit to all the  
navigation programs:

+

2

Upwind pack

Downwind pack

Upwind + Downwind  
pack

OR

OR

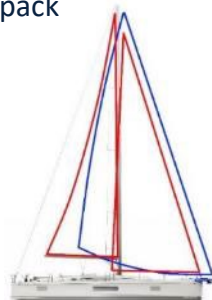
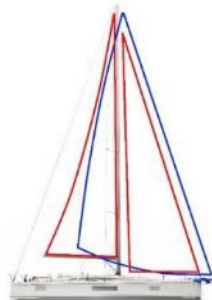

Rigging equipment  
already included in  
First Line Packs

Performance sails  
available as option

Upwind pack: for use of genoa.  
Genoa instead of standard self tacking  
jib and removes traveler on the self-  
tacking jib rail.

Downwind pack: for use of Code 0 or  
spinnaker

Upwind & Downwind pack: for a full  
configuration, this pack associates all the  
equipment

## Rigging Packs

	Downwind Pack	Upwind Pack	Downwind & Upwind Pack
• Symmetrical spinnaker rigging	YES	NO	YES
• Genoa sheet tracks on side decks (removes traveler on the self tacking rail)	NO	YES	YES
• German system (Two-way mainsheet at the helm station)	YES	YES	YES
• 2 Genoa winches (H50.2 STA)	YES	YES	YES
• 2 Additional halyard clutches	YES	NO	YES
• Polyester bowsprit with integrated anchoring gear and bobstay (for Code 0 and asymmetric spinnaker)	YES	NO	YES
• Furling Dacron genoa (to replace the standard self-tacking jib)	NO	YES	YES

### CLASSICAL MAST PACK (compatible with all rigging Packs)

- Classical 9/10 anodised aluminium mast, 2 Spreaders
- Dacron semi Full Batten mainsail (self-tacking jib remains)
- 2 Additional halyard clutches (to port)
- Lazy Jack and Lazy Bag in Natural colour

PERFORMANCE PACKS

# FIRST LINE



Fast





BENETEAU

## FIRST LINE

+28%  
of sail area

TALLER  
mast

! Boat delivered without sails.  
Performance sails as option

HIGH QUALITY  
deck hardware

LIGHTER  
bulb  
DEEPER  
keel

Fast



Delivered without sails. Optional sails available as option	<b>FIRST LINE</b>	Alu	Carbon
<ul style="list-style-type: none"> <li>• Polyester bowsprit with integrated anchoring gear and bobstay (for Code 0 and asymmetric spinnaker)</li> </ul>			✓
<ul style="list-style-type: none"> <li>• Performance Classical mast, 2 Aft swept spreaders (+ 1 m / 3'3"). Track + Main sail ball traveller</li> </ul>		Aluminium mast (Z Diffusion)	Carbon mast (Axxon)
<ul style="list-style-type: none"> <li>• Textile hydraulic backstay</li> </ul>			✓
<ul style="list-style-type: none"> <li>• Black anodised aluminium boom</li> </ul>		x	✓
<ul style="list-style-type: none"> <li>• Cathedral type Dyform standing rigging</li> </ul>			✓
<ul style="list-style-type: none"> <li>• Flatdeck genoa furler</li> </ul>			✓
<ul style="list-style-type: none"> <li>• 4 Additional halyard clutches (2 to starboard + 2 to port)</li> </ul>			✓
<ul style="list-style-type: none"> <li>• Performance running rigging, Dyneema (Mainsail, Genoa, Code 0, Asymmetrical spinnaker, Halyards)</li> </ul>			✓
<ul style="list-style-type: none"> <li>• German system (Two-way mainsheet at the helm station)</li> </ul>			✓
<ul style="list-style-type: none"> <li>• Harken pulleys upgrade</li> </ul>			✓
<ul style="list-style-type: none"> <li>• Genoa sheet tracks on side decks + Complete genoa rigging (Genoa sheets, Return pulleys). Removes traveler on the self tacking rail</li> </ul>			✓
<ul style="list-style-type: none"> <li>• Performa winches upgrade (1 Port electric H46.2 STPEH rigging winch (Halyards) + 1 Starboard manual H46.2 STP rigging winch + 2 Manual H50.2 STP genoa sheet winches)</li> </ul>			✓
<ul style="list-style-type: none"> <li>• Composite steering wheels</li> </ul>		White	Black

## The interior living areas

A big name in design for a particularly elegant interior.

Nauta Design, always mindful to giving our owners the very best, has managed to combine the beauty of fabric and materials, omnipresent light, ergonomics and volume.

A very rich standard in the line of owners' boats.

Mast bookcase, dedicated chart table, large U-shaped sofa, edge capping on the furniture, beige deck linings along the hull, indirect LED lighting, mast upholstery, handrails, view of sea through large ports, easy access with an extremely soft and comfortable companionway.... The 46.1 is an exemplary model

Personalisation certainly isn't overlooked either. Alpi walnut woodwork for a timeless classic or white oak for a more modern twist. Available with lining and upholstery options creating a boat that appeals to all.





#### INTERIOR UPHOLSTERIES



Néo 05- STANDARD

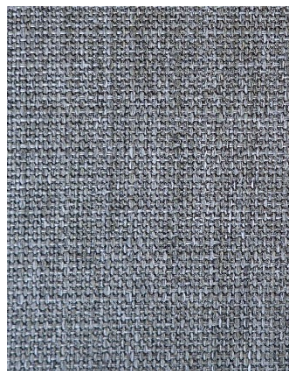

Winner Silver 139- **OPTION**



Marlin Weiss - **OPTION**

#### PADDING



Beige - STANDARD

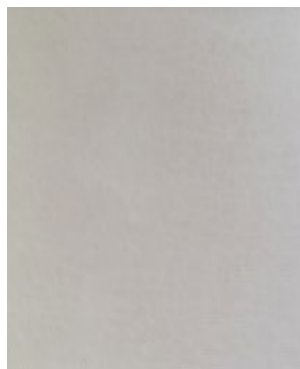

Macadamia - **OPTION**

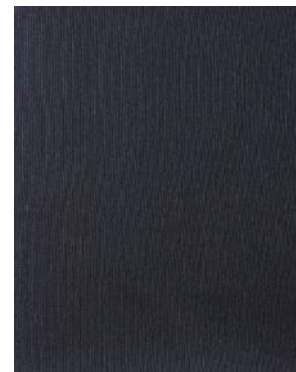

Anthracite - **OPTION**

« Luxe » upholstery options

### Leathers & Nubuck

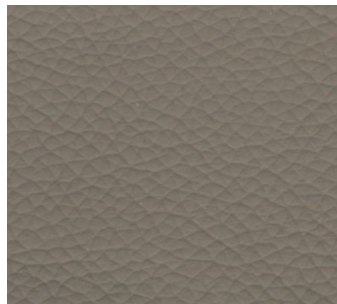

DK 45 (taupe)

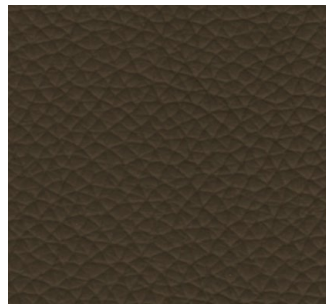

DK 02 (chocolat)

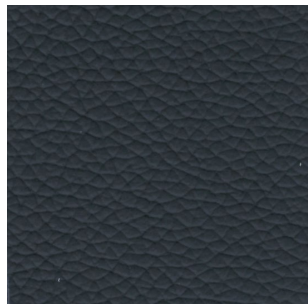

DK 26 (bleu marine)

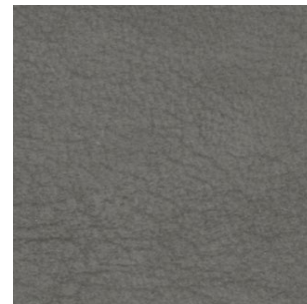

LG 14 (taupe)



LG 13 (chocolat)

### Ultraleather

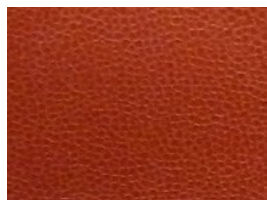

Georgian  
363 8223



Fields  
363 3141

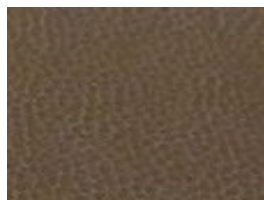

Woodpecker  
363 3462

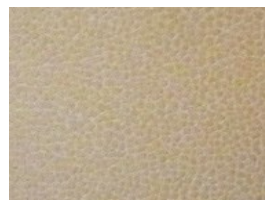

Cocoa  
363 3463



Linen  
363 3036



Parchment  
363 3152



Snow  
363 5715



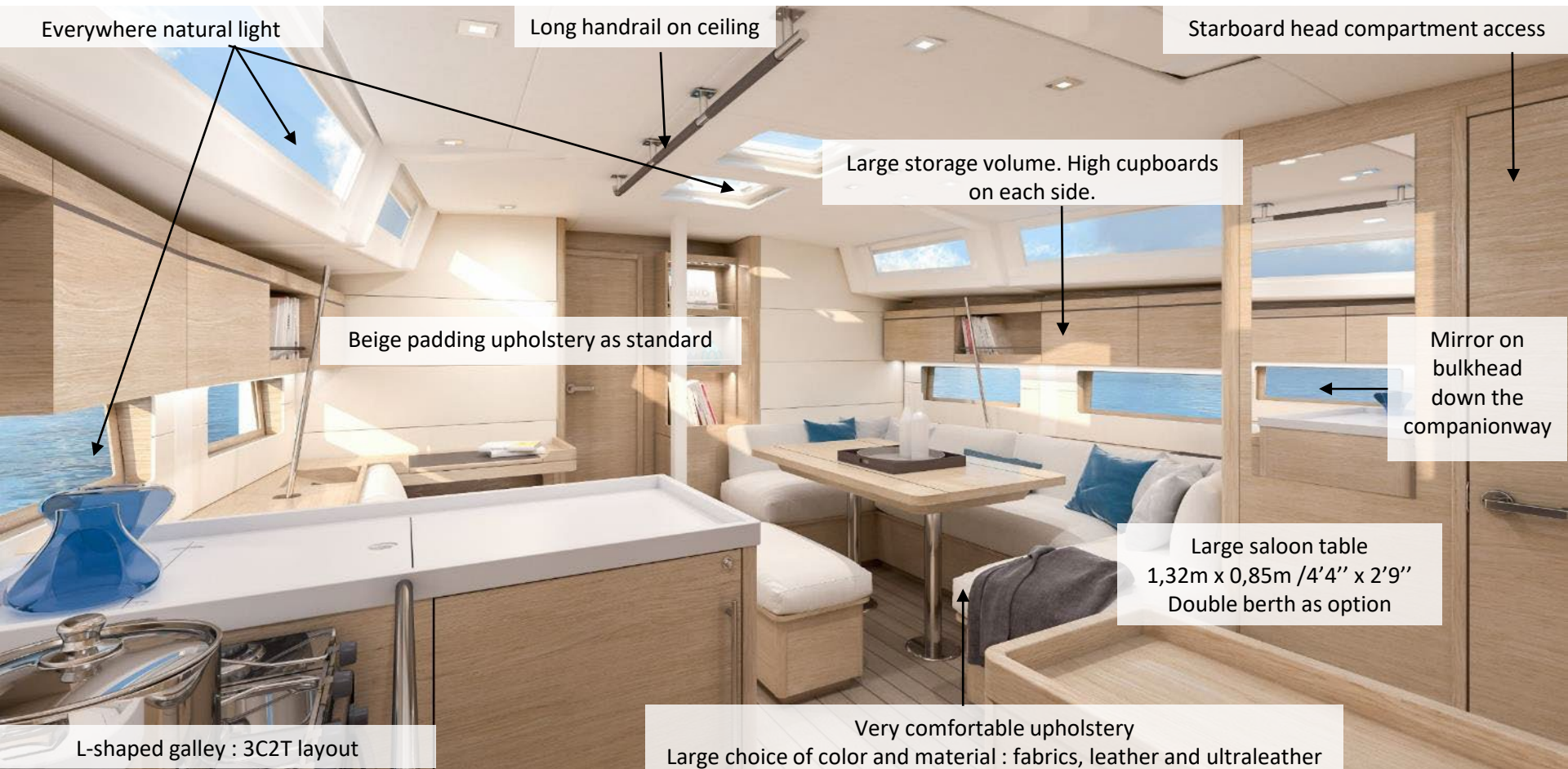

Everywhere natural light

Long handrail on ceiling

Starboard head compartment access

Large storage volume. High cupboards  
on each side.

Beige padding upholstery as standard

Mirror on  
bulkhead  
down the  
companionway

Large saloon table  
1,32m x 0,85m / 4'4" x 2'9"  
Double berth as option

L-shaped galley : 3C2T layout

Very comfortable upholstery  
Large choice of color and material : fabrics, leather and ultra leather

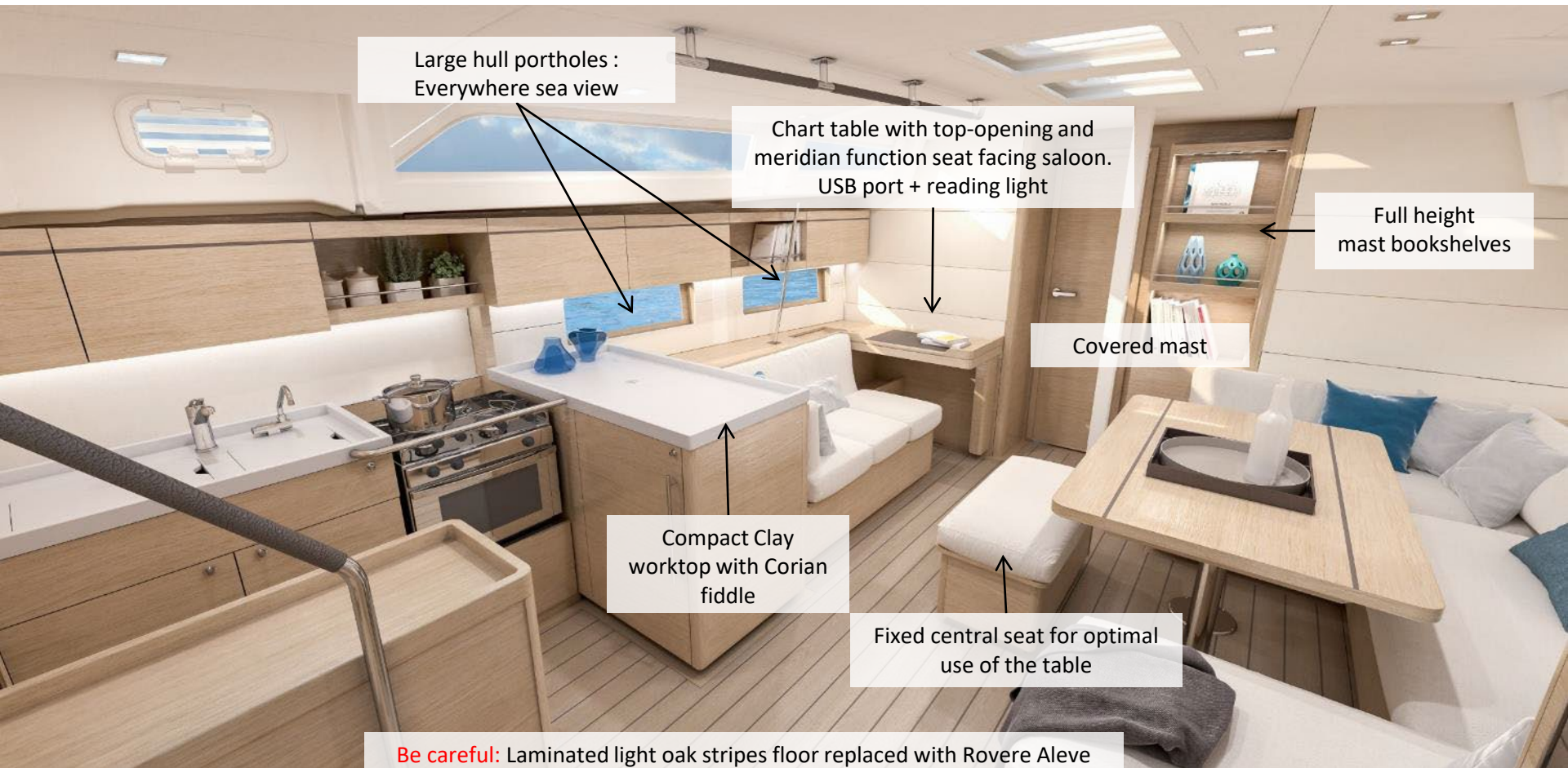



### Galley: qualitative equipment and large volume of storage

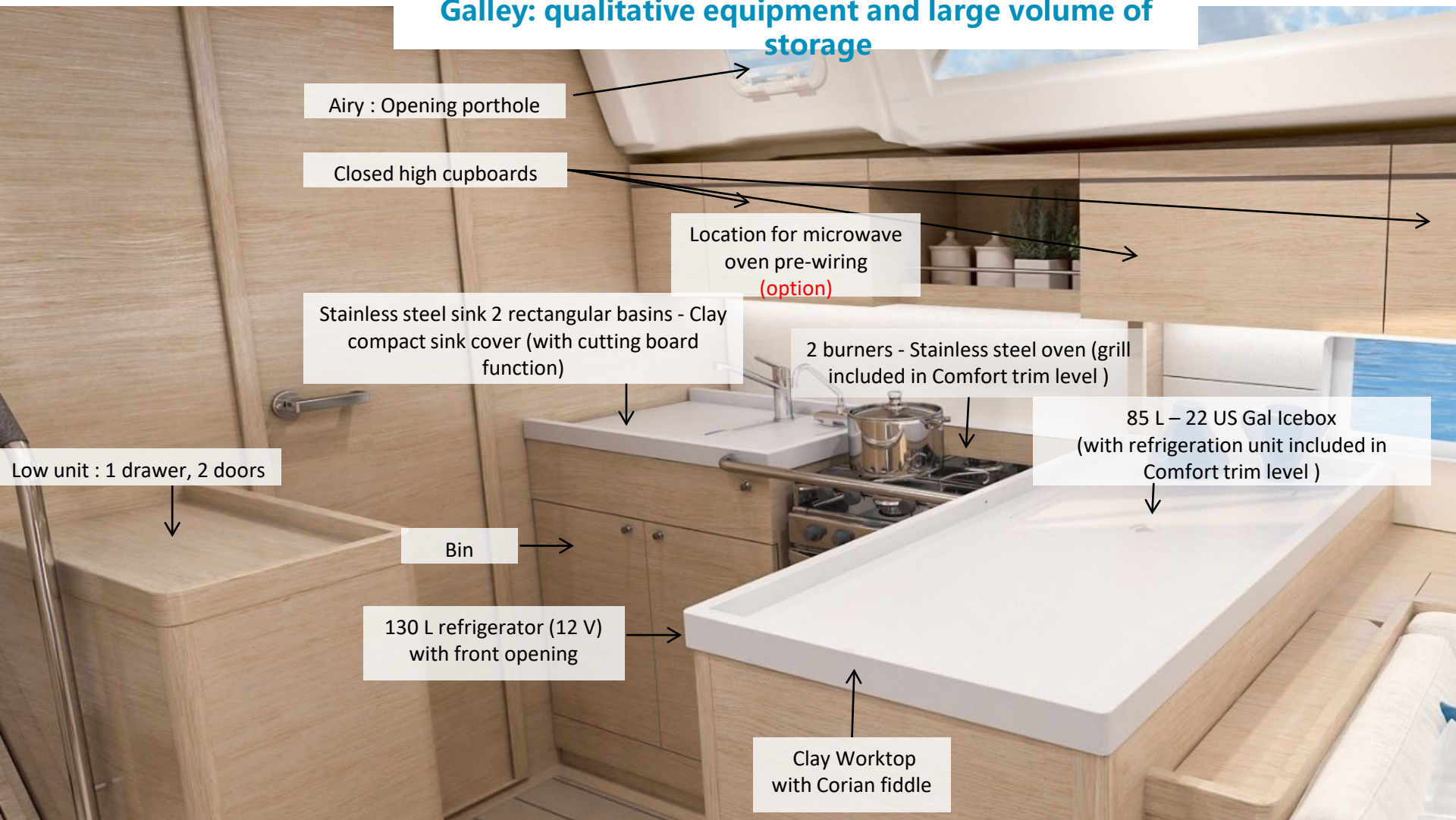

Airy : Opening porthole

Closed high cupboards

Location for microwave oven pre-wiring (option)

Stainless steel sink 2 rectangular basins - Clay compact sink cover (with cutting board function)

2 burners - Stainless steel oven (grill included in Comfort trim level)

85 L – 22 US Gal Icebox (with refrigeration unit included in Comfort trim level)

Low unit : 1 drawer, 2 doors

Bin

130 L refrigerator (12 V) with front opening

Clay Worktop with Corian fiddle

Oceanis 46.1

E-BOOK





### Owner cabin: an unmatched volume and an high-end equipment as standard





## Owner cabin: an unmatched volume and an high-end equipment as standard



### Aft cabins: to welcome guests in full comfort



Bedhead facing aft for a complete comfort

Large volume of storage  
1 wardrobe, 2 closets, 1 cupboard

Sea view  
from the bed

Double berth :  
2,05 x 1,40m / 6'9" x 4'7"

Headroom : 1,92m / 6'4"

## 2. An unbeatable Charter offer

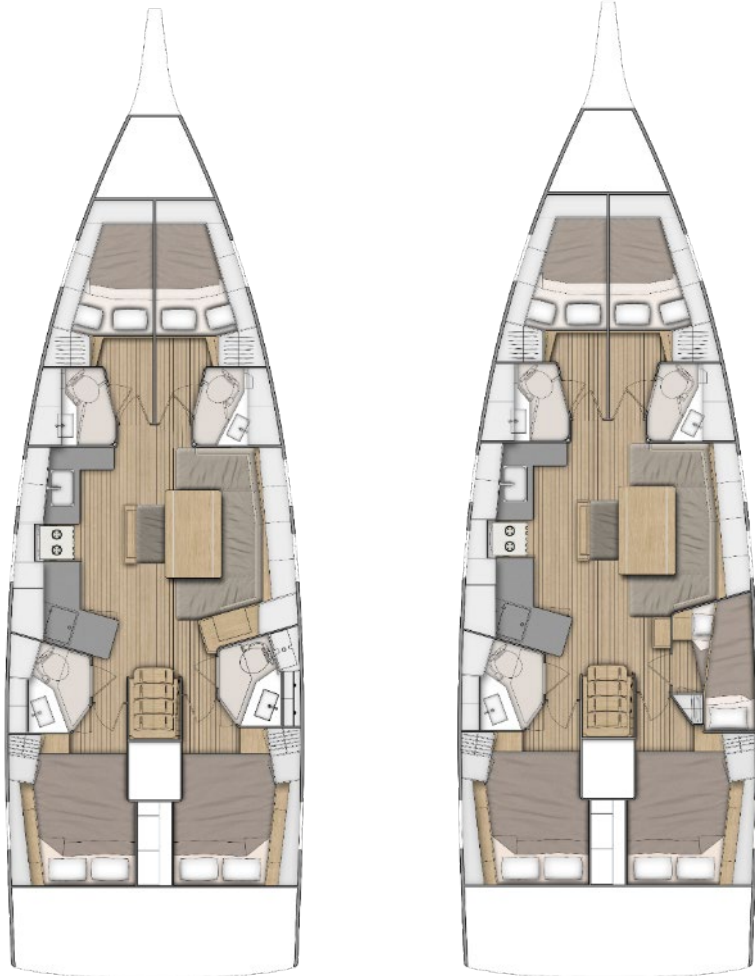

4C4T

5C3T

### An unbeatable Charter offer

The exceptional interior volume of the 46.1 enables some highly attractive and unique versions:

- Double forward cabins with forward facing bedheads twinned with a large bunk:

Length: 2.00m / 6'7"

Bedhead width: 1.36m / 4'6"

Width at foot of bed: 1.16m / 3'10"

Large storage volume: high cupboards, 1 wardrobe, drawer under bed)

Each cabin has its own head!

- Side galley opposite the saloon: large work surface, spacious stowage: designed for meal preparation with numerous guests.

- In the 4C4T version: chart table to starboard near the companionway

- A 5-cabin version on a 46'!

The starboard head and chart table are replaced by a side cabin with bunk beds.

Perfect for the youngest members of the crew



### An unbeatable Charter offer



4C2T

Perfect for customers who want to be in a Yacht Management program and keep the benefit of the large owner's cabin

4C2T

## An unbeatable Charter offer

Privative head compartment



Sea view from the bed



Large storage volume: high cupboards, 1 wardrobe, drawer under bed



Double forward cabins : spacious et bright

An unbeatable Charter offer



Lower bed (2,00 m x 0,60 m - 0,42 m /  
6'7" x 2' - 1'5")



Upper bed (2,04 m x 0,67 m - 0,53 m /  
6'8" x 2'2" - 1'9")

Storage

Side cabin with bunk beds



An unbeatable Charter offer





## An unbeatable Charter offer

85 L ice box with top opening.  
12V refrigerating unit included in  
trim level

Location for  
microwave pre-  
wiring (option)

Stainless steel cooker 2 burners  
& oven on gimbal. Grill included  
in trim level

Large double sink, compact Clay cover  
with cutting board

Convenient bin: with access from the top of the worktop

Storage unit :  
1 cutlery storage drawer, 1 door, 2 shelves

130 L fridge, with  
front opening

Large low storage unit or optional  
6 persons dish-washer pre-wiring

Hughe side galley

Central unit with bottle holder function. Location for the  
optional 32" LED TV pre-wiring on lifting system

Fixed 2 persons central bench

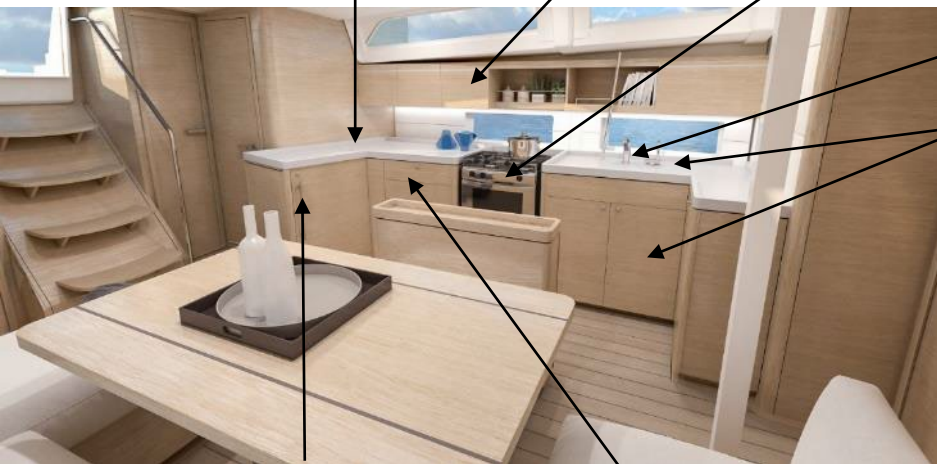

# 3. Ambiance

Walnut alpi + Rovere Alévé floors as standard





White oak alpi + Rovere Alevé floors as option



Brown oak floors option (requires white oak alpi version)



### Offered layouts

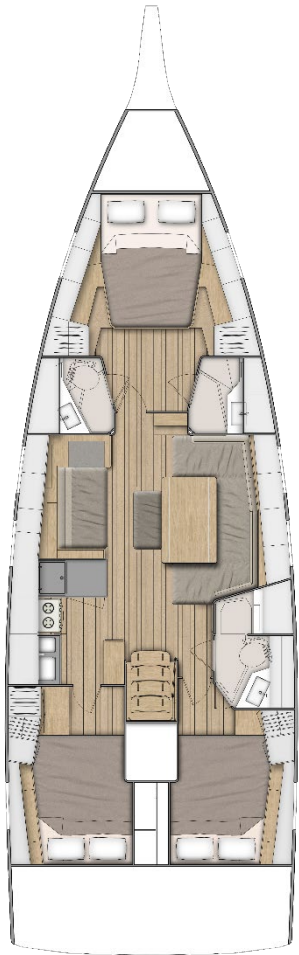

3C2T

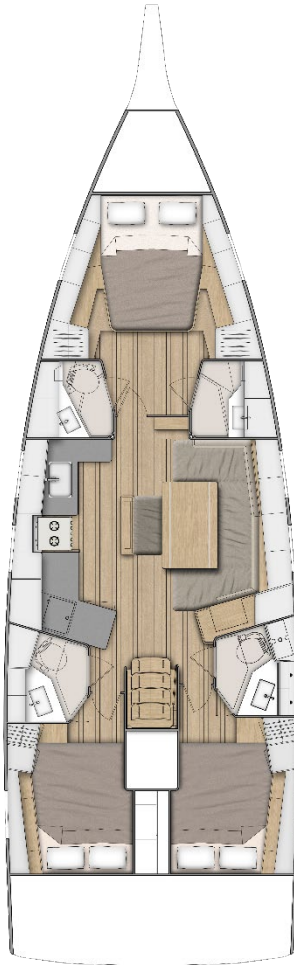

3C3T



4C2T

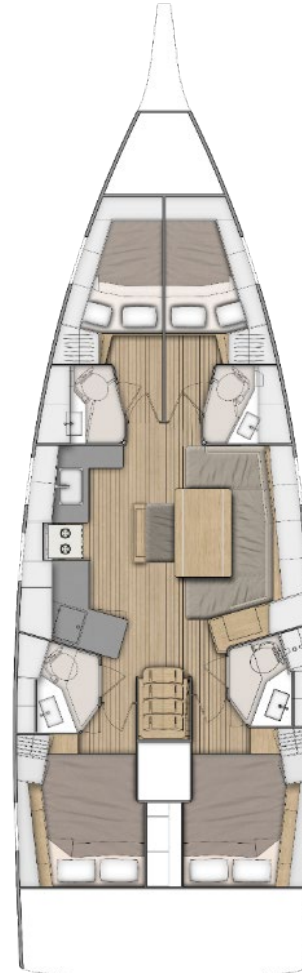

4C4T



5C3T



## 4. Exterior dimensions

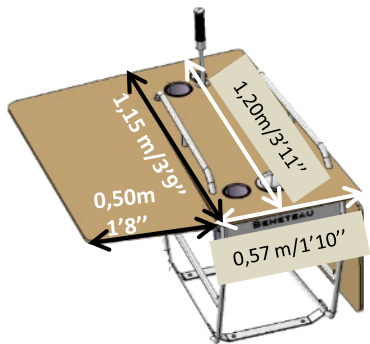

**Standard table**  
 Folded dimension =  
 1,20 m x 0,57 m / 3'11" x 1'10"  
 Wooden leaves =  
 1,15 m x 0,50 m / 3'9" x 1'8"  
 Opened width =  
 1,57 m / 5'2"

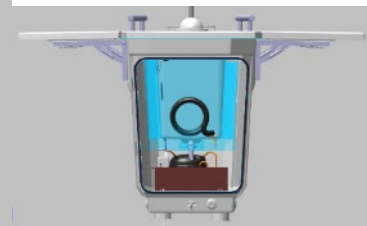
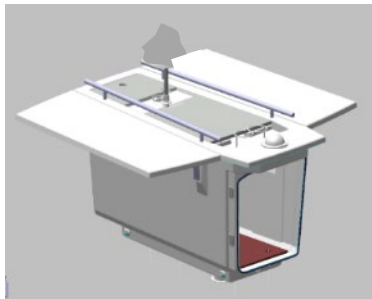

**Luxe table**  
 Folded dimension =  
 1,30 m x 0,50 m / 4'3" x 1'8"  
 Wooden leaves =  
 1,10 m x 0,40 m / 3'7" x 1'4"  
 Opened width =  
 1,35 m / 4'5"

# 5. Interior dimensions



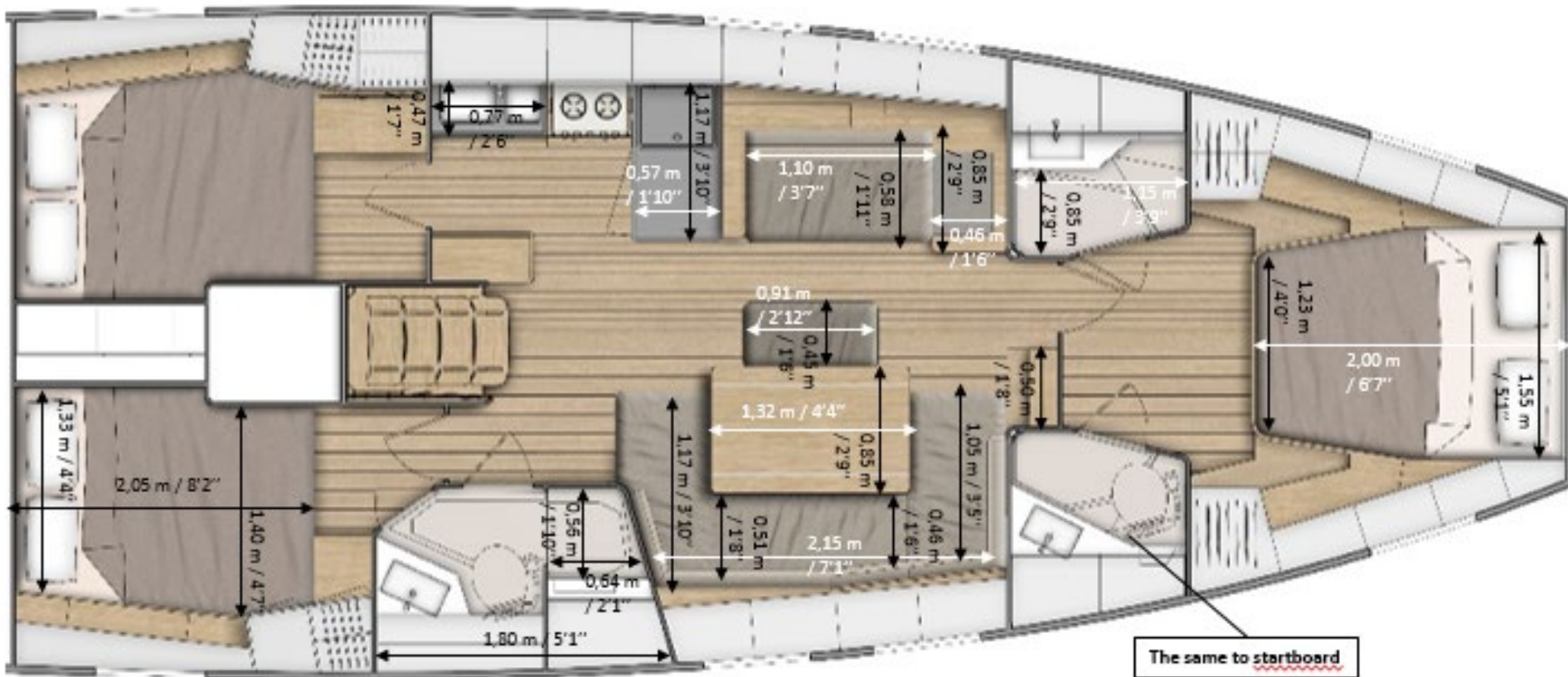

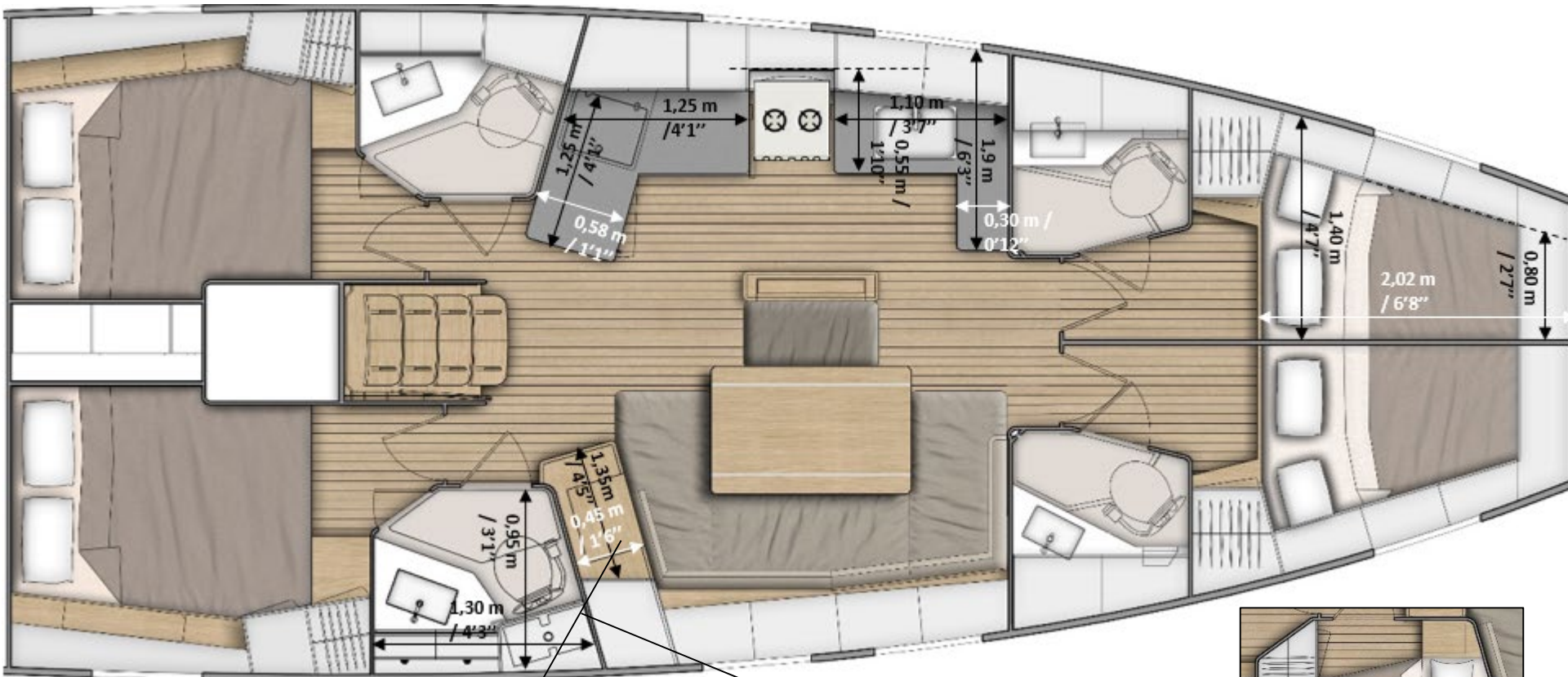

Opening top :  
0,53 m x 0,35 m / 1'9" x 1'2"

Optional side cabin - berth dimension

Lower bed :

Head : 0,60 m / 1'12"

Foot : 0,42 m / 1'5"

Length : 2,00 m / 6'7"

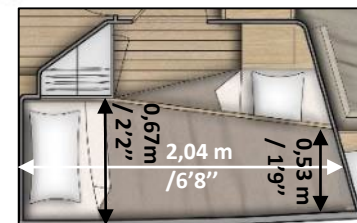

# 6. Headrooms



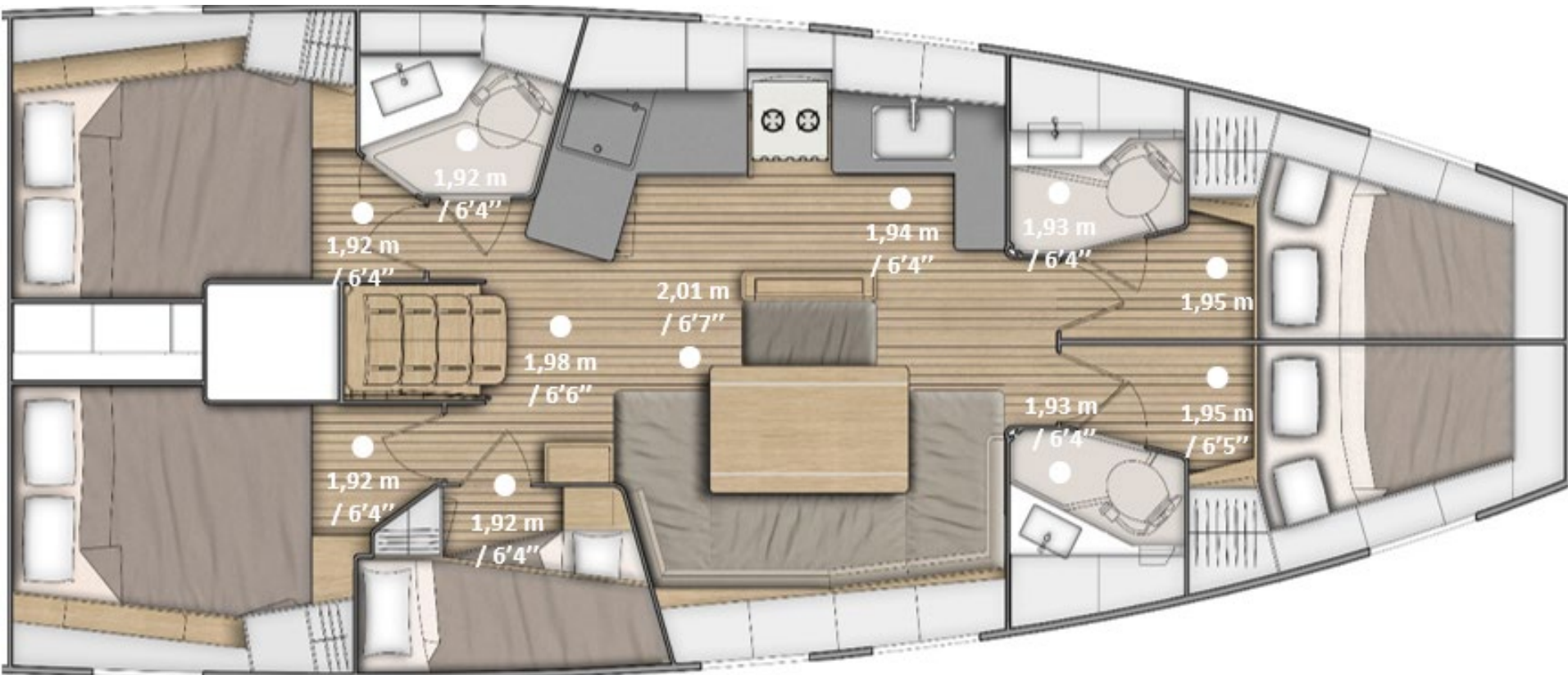

## 7. Location for comfort and technical equipments

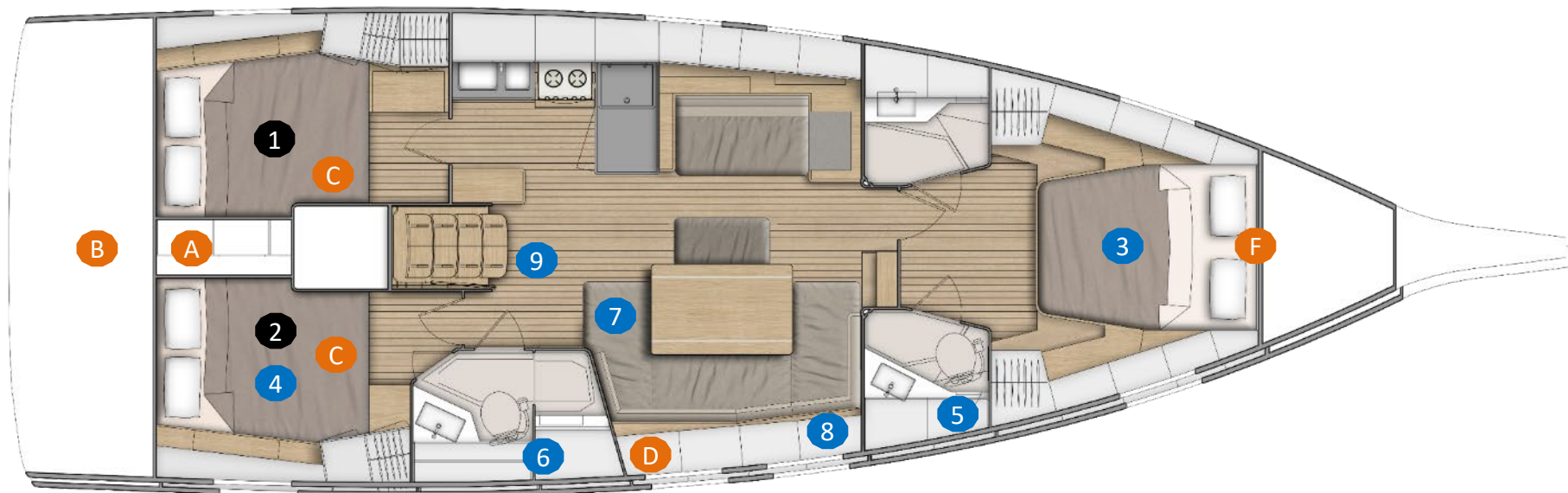





- |          |  |          |   |
|----------|--|----------|---|
| <b>3</b> | Fresh water tank 330 L / 87 US Gal – standard      | <b>1</b> | Fuel tanks 200 L / 53 US Gal - standard                         |
| <b>4</b> | Fresh water tank 200L / 53 US Gal - <b>option</b>  | <b>2</b> | Fuel tanks 200 L / 53 US Gal – <b>option</b>                    |
| <b>5</b> | Holding tank - 50 L / 13 US Gal standard           | <b>A</b> | Pre-wiring generator 7,5 KVA 230V / 50 Hz – <b>option</b>       |
| <b>6</b> | Holding tank - 64 L / 17 US Gal standard           | <b>B</b> | Inverter 12V / 230V - <b>option</b>                             |
| <b>7</b> | Electric water heater 40 L / 11 US Gal - standard  | <b>C</b> | 2 service batteries 120 Ah – 1 engine battery 120 Ah - standard |
| <b>8</b> | Plumbing board (accumulator tank- water units....) | <b>D</b> | Electrical panel  |
| <b>9</b> | Water maker 60 L/h – 16 US Gal/h - <b>option</b>   | <b>F</b> | Bow thruster (+ battey)- <b>option</b>                          |

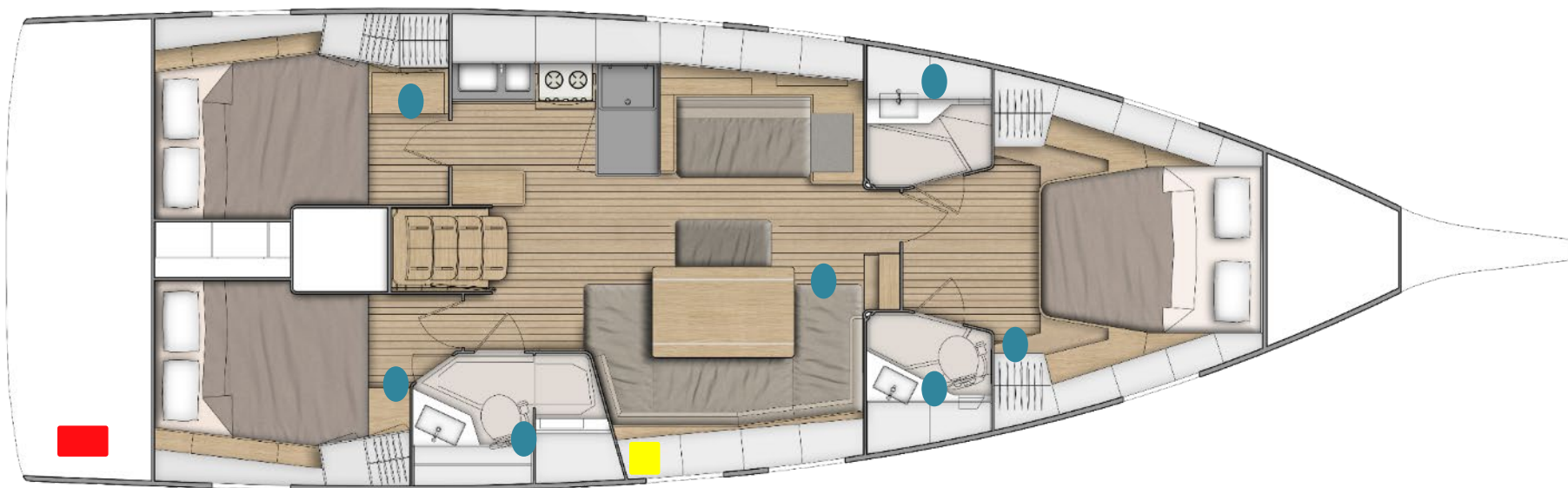

3C2T

## Air heating







-  Boiler 5 500 W
-  Thermostat
-  Hot air outlet

**! Heating not compatible with air conditioning**

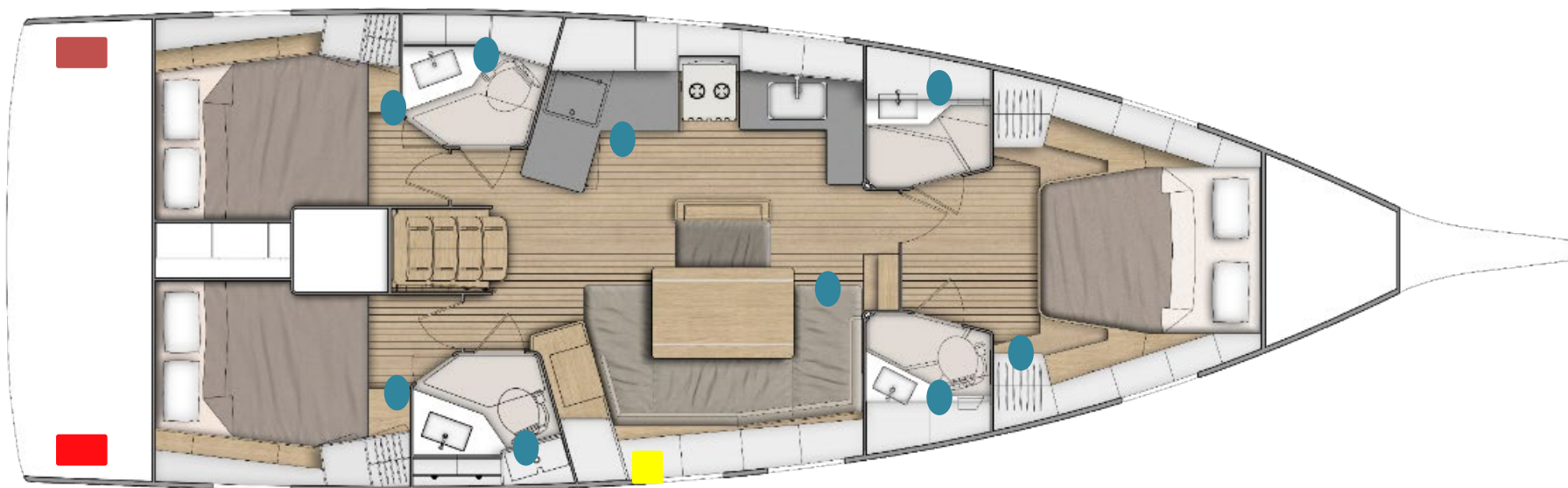
## Air heating

3C3T







-  Boiler 3 900 W
-  Boiler 5 500 W
-  Thermostat
-  Hot air outlet

**! Heating not compatible with air conditioning**

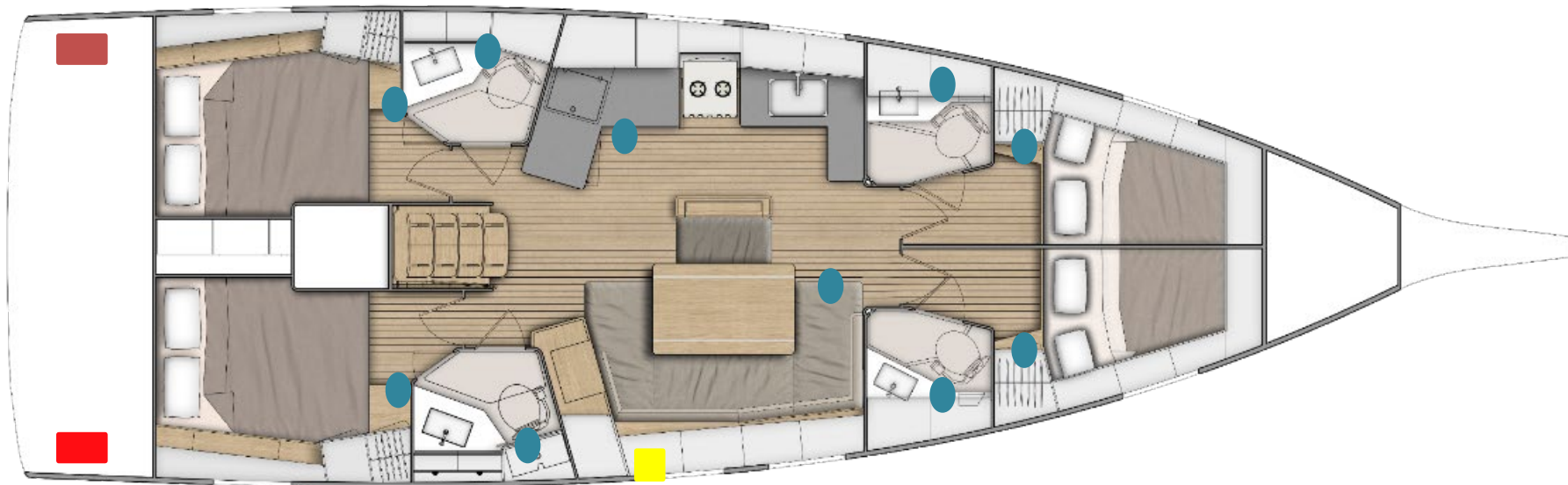
4C4T

## Air heating



-  Boiler 3 900 W
-  Boiler 5 500 W
-  Thermostat
-  Hot air outlet





**! Heating not compatible with air conditioning**

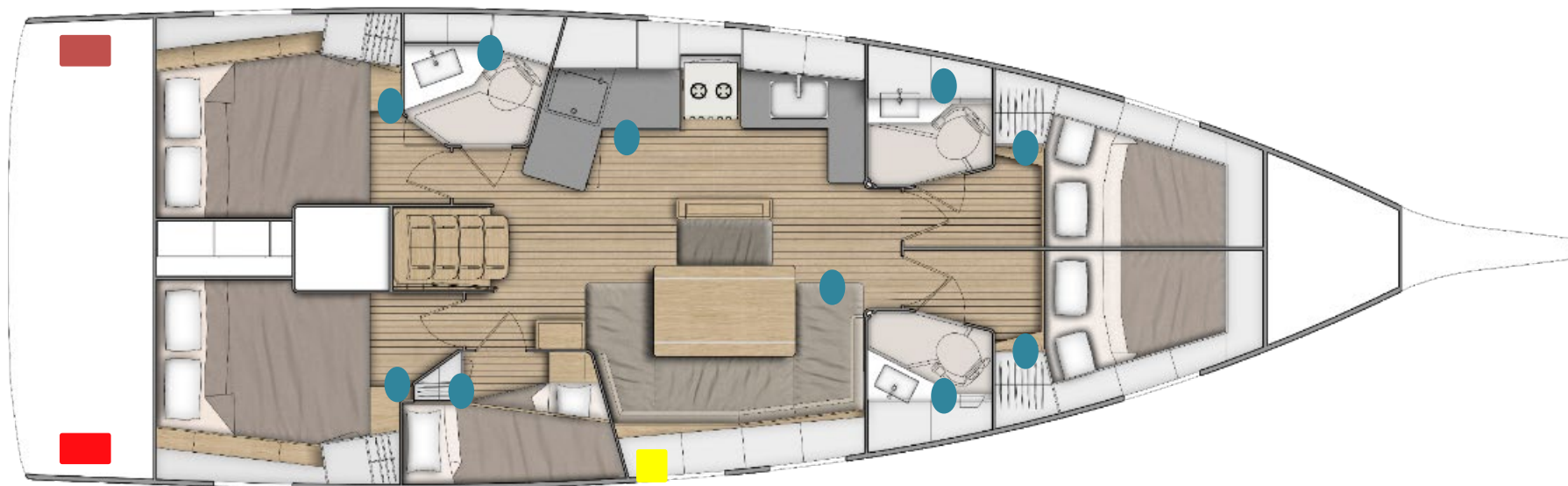

5C3T

## Air heating



-  Boiler 3 900 W
-  Boiler 5 500 W
-  Thermostat
-  Hot air outlet

**! Heating not compatible with air conditioning**



### Air conditioning

3C2T

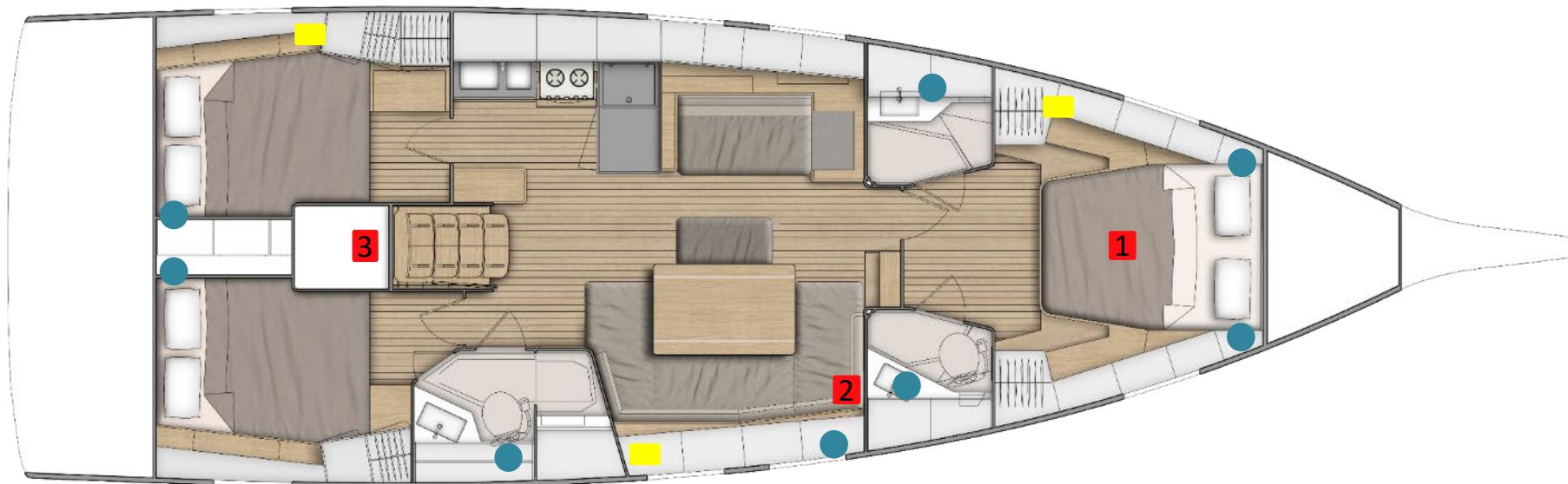
Air conditioning for the saloon and aft cabins



- 1** Air conditioning unit 8 000 BTU
- 2** Air conditioning unit 16 000 BTU
- 3** Pre-wiring air conditioning unit 12 000 BTU

-  Thermostat
-  Air conditioning outlet

**! Air conditioning not compatible with heating**



## Air conditioning

5C3T

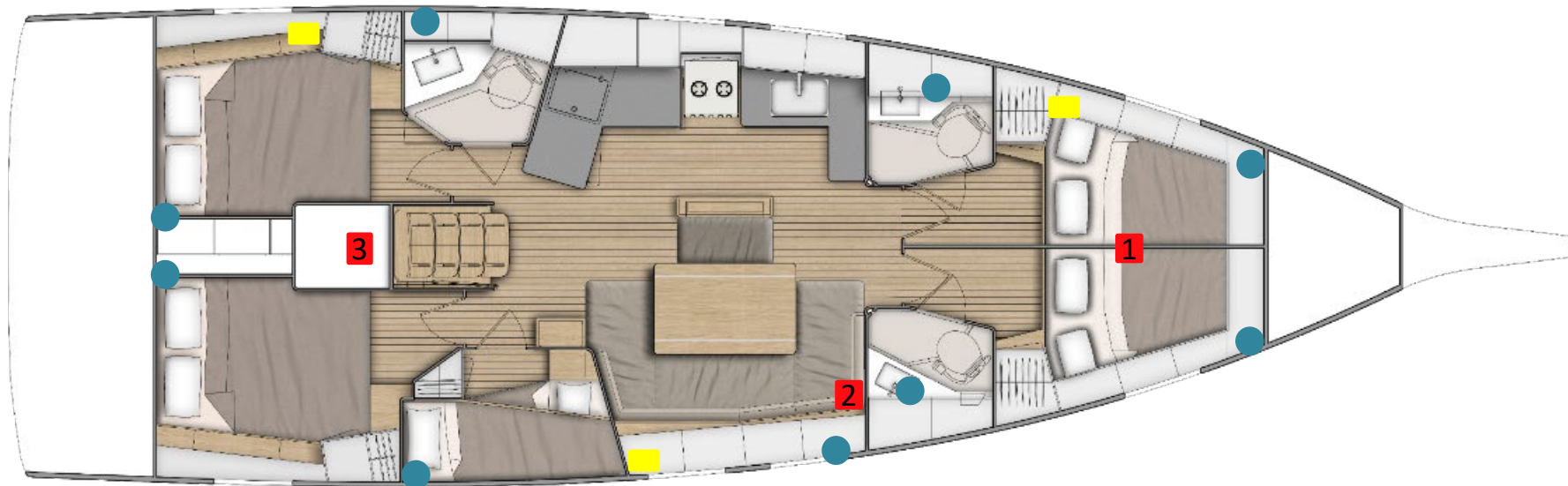
Air conditioning for the saloon and aft cabins



- 1** Air conditioning unit 8 000 BTU
- 2** Air conditioning unit 16 000 BTU
- 3** Pre-wiring air conditioning unit 12 000 BTU

-  Thermostat
-  Air conditioning outlet

**! Air conditioning not compatible with heating**